

**Safety Cages - Appendix J**

**Reglur um öryggisbúr - Viðauki J**

**2016 - Article 253.8**

## ART. 8 SAFETY CAGES

### 8.1 General

The fitting of a safety cage is compulsory.

It may be either:

**a. Fabricated in compliance with the requirements of the following articles (as from Article 253-8.2);**

**b. Homologated or Certified by an ASN according to the homologation regulations for safety cages;**

An authentic copy of the homologation document or certificate, approved by the ASN and signed by qualified technicians representing the manufacturer, must be presented to the competition's scrutineers.

Any new cage which is homologated by an ASN and is on sale, as from 01.01.2003, must be identified by means of an identification plate affixed to it by the manufacturer; this identification plate must be neither copied nor moved (i.e. embedded, engraved or self-destroying sticker).

The identification plate must bear the name of the manufacturer, the homologation or certification number of the ASN homologation form or certificate and the individual series number of the manufacturer.

A certificate bearing the same numbers must be carried on board and be presented to the competition's scrutineers.

**c. Homologated by the FIA according to the homologation regulations for safety cages;**

It must be the subject of an extension (VO) to the homologation form of the vehicle homologated by the FIA.

The manufacturer's identification and a series number must be clearly visible on all cages homologated and sold after 01.01.1997.

The homologation form of the cage must specify how and where this information is indicated, and the purchasers must receive a numbered certificate corresponding to this.

For the following cars, the cage must compulsorily be homologated by the FIA:

VR5 Variant, Super 1600 Kit Variant, Super 2000 Kit Variant, Super 2000 Rally Kit Variant, World Rally Car Variant.

\*\*\*\*\*

## GREIN 8 ÖRYGGISBÚR

### 8.1 Almennt

Skylt er að koma fyrir öryggisbúri.

Það getur verið annað hvort:

**a. Smíðað í samræmi við kröfur eftirfarandi greina (frá og með grein 253-8.2);**

**b. Gerðarvottað eða vottað af akstursípróttasambandi í samræmi við reglur um gerðarvottun fyrir öryggisbúr;**

Staðfest afrit af skjölum eða vottorði gerðarvottunar, samþykkt af akstursípróttasambandi og undirritað af hæfum tæknimönnum framleiðanda, sem skoðunarmönnum keppni skal sýnt.

Sérhvert nýtt búr sem er gerðarvottað af akstursípróttasambandi og er til sölu frá og með 01.01.2003, skal vera merkt með auðkennismerki sem framleiðandi setur á það; hvorki má afrita né færa þetta auðkennismerki (innfellt, útskorið eða sjálfseyðandi límmiði).

Auðkennismerkið skal vera með nafn framleiðanda, númer gerðarvottunar eða vottorðs ásamt einkvæmu raðnúmeri framleiðanda.

Vottorð með sömu númerum verður að fylgja með ökutæki og framvísað skoðunarmönnum keppinnar.

**c. Gerðarvottuð af FIA samkvæmt reglum um gerðarvottun öryggisbúra;**

Skal vera háð framlengingu gerðarvottunarskjala ökutækis sem FIA hefur gerðarvottað.

Auðkennismerki framleiðanda og raðnúmer skulu vera vel sýnileg á öllum búrum sem voru gerðarvottuð og seld eftir 01.01.1997.

Í gerðarvottunarskjölum búrs skal tilgreina hvernig og hvar þessar upplýsingar koma fram, og kaupendur verða að fá númerað vottorð sem samsvarar þessu.

Fyrir eftirtalin ökutæki, skal búrið vera gerðarvottað af FIA:

VR5 Variant, Super 1600 Kit Variant, Super 2000 Kit Variant, Super 2000 Rally Kit Variant, World Rally Car Variant.

\*\*\*\*\*

Allar breytingar á gerðarvottuðu eða vottuðu öryggisbúri eru bannaðar.

Litið er á sem breytingu, hvaða aðgerð sem gerð er á búrinu með vinnslu eða suðu, sem felur í sér varanlega breytingu á efninu eða öryggisbúrinu.

<p>Any modification to a homologated or certified safety cage is forbidden. To be considered as a modification, any process made to the cage by machining, welding, that involves a permanent modification of the material or the safety cage. All repairs to a homologated or certified safety cage, damaged after an accident must be carried out by the manufacturer of the cage or with his approval. The chromium plating of all or part of the cage is forbidden. Tubes of the safety cages must not carry fluids or any other item.</p> <p>The safety cages must not unduly impede the entry or exit of the driver and co-driver. <u>Inside the cockpit, the passage of the following elements between the side members of the bodyshell and the safety cage is forbidden:</u></p> <ul style="list-style-type: none"> <li>• Electric cables</li> <li>• Lines carrying fluids (except windscreen washer fluid)</li> <li>• Lines of the extinguishing system.</li> </ul> <p>Members may intrude into the occupant's space in passing through the dashboard and trim, as well as through the rear seats.</p> <p>The rear seat may be folded down.</p>	<p>Allar viðgerðir á gerðarvottuðu eða vottuðu búi sem skemmist við óhapp skulu vera framkvæmdar af framleiðanda búrsins eða með samþykki hans. Krómhúðun búrsins að heild eða hluta er bönnuð. Rör í öryggisbúrum mega hvorki innihalda vökva né önnur efni.</p> <p>Öryggisbúr má ekki hindra að óþörfu að ökumaður eða aðstoðarökumaður komist inn eða út. <u>Í stjórnklefa er tenging eftirfarandi milli hliða yfirbyggingar og öryggisbúrsins bönnuð:</u></p> <ul style="list-style-type: none"> <li>• Rafmagnsvírar</li> <li>• Slöngur með vökva (fyrir utan þvottavökva framrúðunnar)</li> <li>• Slöngur slökkvikerfis</li> </ul> <p>Rör mega ná inn í farþegarými þegar þau fara í gegnum mælaborð og klæðningu, sem og í gegnum aftursætin.</p> <p>Aftursæti má fella niður.</p>
<p><b>8.2 Definitions</b> <b>8.2.1 Safety cage</b> Multi-tubular structure installed in the cockpit and fitted close to the bodyshell, the function of which is to reduce the deformation of the bodyshell (chassis) in case of an impact.</p>	<p><b>8.2 SKILGREININGAR</b> <b>8.2.1 ÖRYGGISBÚR (safety cage)</b> Grind gerð úr fjölda röra sem eru sett inní farþegarými keppnistækis og er komið fyrir mjög nálægt yfirbyggingu þess. Markmiðið er að minnka afmyndun yfirbyggingarinnar verði hún fyrir höggi.</p>
<p><b>8.2.2 Rollbar</b> Tubular frame forming a hoop with two mounting feet.</p>	<p><b>8.2.2 VELTIBOGI (rollbar)</b> Rammi eða bogi úr röri sem hefur tvær fótplötur og myndar boga.</p>
<p><b>8.2.3 Main rollbar (Drawing 253-1)</b> Transverse and near-vertical (maximum angle +/-10° to the vertical) single piece tubular hoop located across the vehicle just behind the front seats. The tube axis must be within one single plane.</p>	<p><b>8.2.3 AÐALVELTIBOGI (main rollbar - teikning 253-1)</b> Tvíhliða og nær lóðréttur (horn að hámarki +/- 10° frá lóðréttu) ósamsettur bogi sem liggur yfir keppnistækinu rétt fyrir aftan framsæti. Þversnið verður að vera innan eins flatar.</p>
<p><b>8.2.4 Front rollbar (Drawing 253-1)</b> Similar to main rollbar but its shape follows the windscreen pillars and top screen edge.</p>	<p><b>8.2.4 FREMRI VELTIBOGI (front rollbar - teikning 253-1)</b> Veltibogi þar sem lögun fylgir stoðum og efri brún framrúðu (þar sem framrúða er á annað borð).</p>
<p><b>8.2.5 Lateral rollbar (Drawing 253-2)</b> Near-longitudinal and near-vertical single piece tubular hoop located along the right or left side of the vehicle, the front pillar of which follows the windscreen pillar and the</p>	<p><b>8.2.5 LANGTENGÐUR VELTIBOGI (lateral rollbar - teikning 253-2)</b> Langtengdur og nær-lóðréttur ósamsettur bogi, staðsettur meðfram annarri hlið keppnistækisins. Fremri súla fylgi stoðum framrúðu. Aftari súla, sem er nær lóðrétt, skal</p>

rear pillar of which is near-vertical and located just behind the front seats. The rear pillar must be straight in side view.	staðsett rétt fyrir aftan framsæti. Baksúlur skulu vera beinar séð frá hlið.
<b>8.2.6 Lateral half-rollbar (Drawing 253-3)</b> Identical to the lateral rollbar but without the rear pillar.	<b>8.2.6 LANGTENGÐUR HÁLF-VELTIBOGI (lateral half-rollbar - teikning 253-3)</b> Veltibogi staðsettur rétt fyrir aftan framsæti þar sem lögun fylgir keppnistækis eins og um aðalveltiboga væri að ræða. Langtengdar stoðir eru festar við hann og gluggastykki yfir framglugga.
<b>8.2.7 Longitudinal member</b> Near-longitudinal single piece tube joining the upper parts of the front and main rollbars.	<b>8.2.7 LENGÐARSTÍFUR (longitudinal member)</b> Ósamsettar stífur nálægt lengdarlínu sem tengja saman efri hluta fram- og aðalveltiboga.
<b>8.2.8 Transverse member</b> Near-transverse single piece tube joining the upper parts of the lateral half-rollbars or of the lateral rollbars.	<b>8.2.8 ÞVERSTÍFUR (transverse member)</b> Tvö ósamsett rör sem tengja efri hluta langtengdra veltiboga eða hálf-veltiboga.
<b>8.2.9 Diagonal member</b> <b>Transverse tube between :</b> One of the top corners of the main rollbar, or one of the ends of the transverse member in the case of a lateral rollbar, and at the lower mounting point on the opposite side of the rollbar. or The upper end of a backstay and the lower mounting point of the other backstay.	<b>8.2.9 SKÁSTÍFUR (diagonal member)</b> Rör sem tengja saman efri horn aðalveltiboga, eða efri afturhorn langtendra veltiboga við neðri festingu veltibogans á gagnstæðu hliðinni. eða efri enda annarrar bakstífu við neðri festingu gagnstæðu bakstífunnar.
<b>8.2.10 Removable members</b> Members of a safety cage which must be able to be removed.	<b>8.2.10 LAUSTENGD STÍFA (removable member)</b> Hluti af öryggisbúri sem hægt er að fjarlægja með því að losa bolta.
<b>8.2.11 Cage reinforcement</b> Member added to the safety cage to improve its strength.	<b>8.2.11 STYRKSTARSTÍFA (cage reinforcement)</b> Aukastífa sem bætt er við öryggisbúr til að auka styrk.
<b>8.2.12 Mounting foot</b> Plate welded to the end of a rollbar tube to permit its bolting to the bodyshell/chassis, usually onto a reinforcement plate.  This plate may be welded to the bodyshell/chassis in addition to the bolts.	<b>8.2.12 FÓTPLATA (mounting foot)</b> Plata sem er soðin í neðri enda veltiboga eða stífu, til að hægt sé að bolta og / eða sjóða við yfirbyggingu eða grind.  Fyrir utan að bolta þessa plötu má einnig sjóða hana við yfirbyggingu/grind.
<b>8.2.13 Reinforcement plate</b> Metal plate fixed to the bodyshell/chassis under a rollbar mounting foot to better spread the load onto the bodyshell/chassis.	<b>8.2.9 STYRKSTARPLATA (reinforcement plate)</b> Plata sem er fest við grind eða undirvagn til að styðja við fótplötu og dreifa álagi á fótplötuna betur.

### 8.2.14 Gusset (Drawing 253-34)

Reinforcement for a bend or junction made from bent sheet metal with a U shape the thickness of which must not be less than 1.0 mm.

The ends of this gusset (point E) must be situated at a distance from the top of the angle (point S) of between 2 to 4 times the outer diameter of the biggest of the tubes joined.

A cut-out is permitted at the top of the angle but its radius (R) must be no greater than 1.5 times the outer diameter of the biggest of the tubes joined.

The flat sides of the gusset may have a hole the diameter of which must not be greater than the outer diameter of the biggest of the tubes joined.

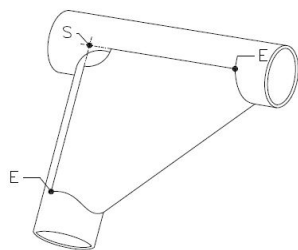

### 8.2.14 ÁFELLA (gusset - teikning 253-34):

Styrking úr málmplötu sem er ekki minna en 1,0 mm þykk, mótað í U-form og soðið í beygju eða samskeyti. Endinn á áfellunni (E) skal vera á milli tvisvar og fjórum sinnum þvermál stærra rörsins sem tengist.

Heimilt er að skera úr innra horni en radius má ekki vera meiri en 1,5 sinnum ytra þvermál stærra rörsins.

Flatar hliðar áfellunnar mega hafa göt en þvermál þeirra skal aldrei vera meira en þvermál stærra rörsins sem tengist

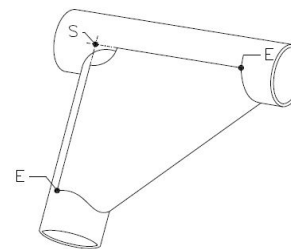

### 8.2.15 BAKSTÍFA (backstay):

Bein stífa samsíða hlið keppnistækisins frá efri hluta veltibogans niður í gólf eða grind keppnistækisins.

## 8.3 Specifications

### 8.3.1 Basic structure

The basic structure must be made according to one of the following designs :

- 1 main rollbar + 1 front rollbar + 2 longitudinal members + 2 backstays + 6 mounting feet (Drawing 253-1)

or

- 2 lateral rollbars + 2 transverse members + 2 backstays + 6 mounting feet (Drawing 253-2)

or

- 1 main rollbar + 2 lateral half-rollbars + 1 transverse member + 2 backstays + 6 mounting feet (Drawing 253-3)

## 8.3 Forskriftir

### 8.3.1 Grunn uppbygging

Grunn uppbygging þarf að vera byggð á eftirfarandi hönnun:

- 1 aðalbogi + 1 fremri veltiboga + 2 lengdarstífur + 2 bakstífur + 6 fótplötur (teikning 253-1)

eða

- 2 langtengdir veltibogar + 2 þverstífur + 2 bakstífur + 6 fótplötur (teikning 253-2)

eða

- 1 aðalbogi + 2 langtengdir hálf-veltibogar + 1 þverstífa + 2 bakstífur + 6 fótplötur (teikning 253-3)

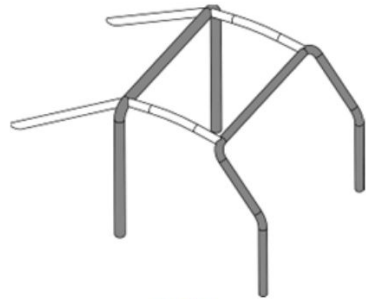

253-1

*Aðalveltibogi*

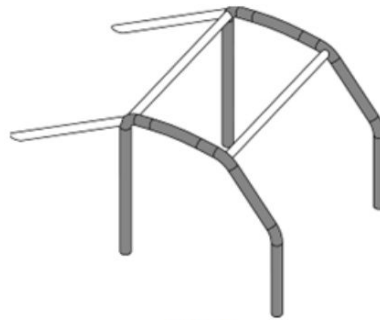

253-2

*Langtengdur veltibogi*

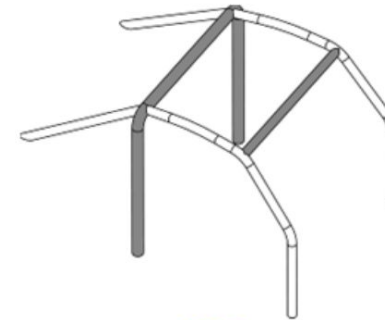

253-3

*Langtengdur hálf-veltibogi*

The vertical part of the main rollbar must be as close as possible to the interior contour of the bodyshell and must have only one bend with its lower vertical part.

The front pillar of a front rollbar or of a lateral rollbar must follow the windscreen pillars as closely as possible and have only one bend with its lower vertical part.

In order to build the safety cage, the connections of the transverse members to the lateral rollbars, the connections of the longitudinal members to the front and main rollbars, as well as the connection of a semi-lateral rollbar to the main rollbar must be situated at the roof level.

In all cases, there must not be more than 4 removable connections at the roof level.

The backstays must be attached near the roofline and near the top outer bends of the main rollbar, on both sides of the car, possibly by means of removable connections.

They must form an angle of at least 30° with the vertical, must run rearwards and be straight and as close as possible to the interior side panels of the bodyshell.

Lárétti hluti aðalveltibogans skal vera eins nærri yfirbyggingu og má aðeins hafa eina beygju yfir í lóðrétta hluta bogans.

Framstífan á fremri veltiboga eða langtengdum veltiboga þarf að fylgja gluggastykki eins nærri og hægt er og vera einungis með eina beygju við lóðréttan neðri hlutann.

Til þess að smíða öryggisbúr skulu, tengingar þverstífa við langtengdan veltiboga, tengingar lengdarstífa við fremri- og aðalboga, og tengingar langtengds veltiboga við aðalveltiboga vera staðsettar við þak.

Í öllum tilfellum skulu ekki vera fleiri en 4 laustengdar stífur við þak.

Bakstífur þurfa að vera tengdar nærri þaki og nálægt efri hluta á beygjum aðalboga á báðum hliðum bílsins, hugsanlega með notkun laustengdra stífa.

Þær skulu ekki hafa minni halla en 30° miðað við lóðréttar stífur, í átt að afturenda, vera beinar og eins nálægt hlið yfirbyggingar og hægt er.

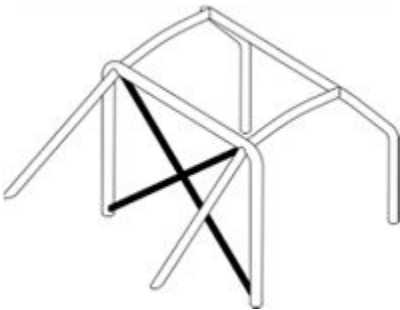
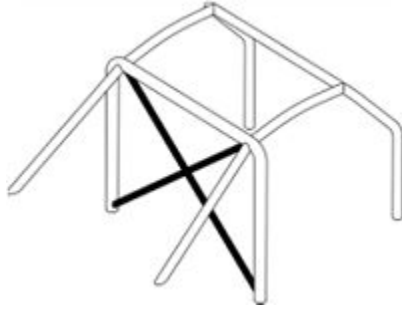
<p><b>8.3.2 Design</b></p> <p>Once the basic structure is defined, it must be completed with compulsory members and reinforcements (see Article 253-8.3.2.1), to which optional members and reinforcements may be added (see facultatifs (voir Article 253-8.3.2.2).</p> <p>Unless explicitly permitted and unless dismountable joints are used in compliance with Article 253-8.3.2.4, all members and tubular reinforcements must be single pieces.</p>	<p><b>8.3.2 Hönnun</b></p> <p>Þegar grunn uppbygging hefur verið ákveðin skal bæta við skyldustífum og styrkingum (sjá grein 253-8.3.2.1). Við þær má bæta aukastífum og styrkingum (sjá grein 253-8.3.2.2).</p> <p>Sé það ekki sérstaklega leyft og eða laustengdar stífur notaðar í samræmi við grein 253-8.3.2.4, verða allar stífur og styrkingar að vera úr ósamsettum rörum.</p>
<p><b>8.3.2.1 Compulsory members and reinforcements</b></p> <p><b>8.3.2.1.1 Diagonal member</b></p> <p>The cage must have two diagonal members on the main rollbar according to Drawing 253-7.</p> <p>Members must be straight and may be removable.</p> <p>The lower end of the diagonal must join the main rollbar no further than 100 mm from the mounting foot (see Drawing 253-52 for the measurement).</p> <p>The upper end of the diagonal must join the main rollbar no further than 100 mm from its junction with the backstay.</p>  <p style="text-align: center;">253-7</p>	<p><b>8.3.2.1 Skyldustífur og styrkingar</b></p> <p><b>8.3.2.1.1 Skástífur</b></p> <p>Búrið verður að hafa tvær skástífur í aðalboga, sjá teikningu 253-7. Stífur verða að vera beinar og mega vera færanlegar. Neðri endi skástífanna verður að tengjast aðalboga, ekki hærra uppi en 100mm frá fótplötu (sjá teikningu 253-52 fyrir málsetningar). Efri endi skástífanna verður að tengjast aðalboga innan 100mm frá samskeytum við bakstífuna.</p>  <p style="text-align: center;">253-7</p>
<p><b>8.3.2.1.2 Doorbars</b></p> <p>One or more longitudinal members must be fitted at each side of the vehicle according to Drawings 253-9, 253-10 and 253-11. Drawings may be combined. The design must be identical on both sides. They may be removable. The side protection must be as high as possible, but its upper attachment point must not be higher than half the height of the door opening measured from its base.</p>	<p><b>8.3.2.1.2 Hurðabitar</b></p> <p>Tveim eða fleiri lengdarstífum skal vera komið fyrir á hvorri hlið keppnistækis í samræmi við teikningar, 253-9, 253-10 og 253-11. Sameina má teikningar. Hönnun skal vera eins á báðum hliðum. Hurðabitar mega vera laustengdir. Hliðarvörninn skal vera eins ofarlega og hægt er, en efri tengipunktur má ekki vera hærri en hálf hæð hurðaropsins mælt að neðan.</p>

If these upper attachment points are located in front of or behind the door opening, this height limitation is also valid for the corresponding intersection of the strut and the door opening.

In the case of doorbars in the form of an "X" (Drawing 253-9), it is recommended that the lower attachment points of the cross-struts be fixed directly onto the longitudinal member of the bodyshell/chassis and that at least one part of the "X" be a singlepiece bar.

The connection of the doorbars to the windscreen pillar reinforcement (Drawing 253-15) is authorised.

For competitions without co-driver, members may be fitted on the driver's side only and it is not compulsory for the design to be identical on both sides.

Þegar efri tengipunktur eru staðsettir framan eða aftan við hurðaropið, gildir þessi hæðartakmörkun einnig fyrir samsvarandi tengingar fjöðrunarturns og hurðaropsins.

Þegar hurðabitar mynda "X" (teikning 253-9) er mælt með því að neðri tengipunktur séu við fótplötu búrsins og annar hurðarbitinn skal vera heill.

Heimilt er að tengja hurðarbita við gluggastífu (teikning 253-15).

Fyrir keppnir án aðstoðarökumanns, má setja stífur eingöngu ökumannsmegin og þá er ekki skylda að hönnun sé eins á báðum hliðum.

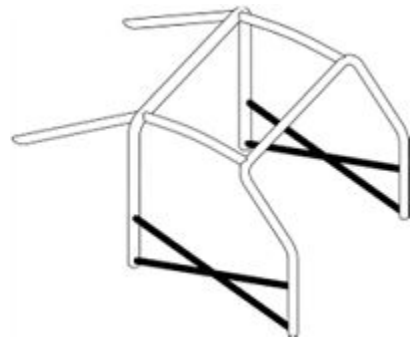

253-9

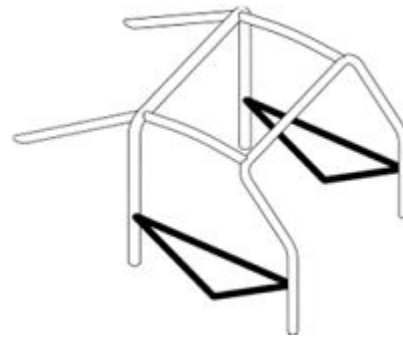

253-10

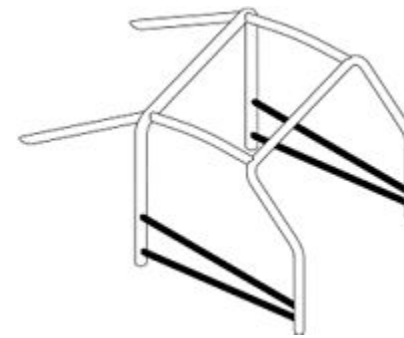

253-11

#### 8.3.2.1.3 Roof reinforcement

The upper part of the safety cage must comply with one of Drawings 253-12, 253-13 and 253-14.

The reinforcements may follow the curve of the roof.

For competitions without co-drivers, in the case of Drawing 253-12 only, only one diagonal member may be fitted but its front connection must be on the driver's side.

The ends of the reinforcements must be less than 100 mm from the junction between rollbars and members (not applicable to the top of the V formed by reinforcements in Drawings 253-13 and 253-14).

##### Junction of tubes at the top of the V :

If the tubes do not join each other, the distance between them must not be more than 100 mm at their connection with the rollbar or the transverse member.

#### 8.3.2.1.3 Þakstyrkingar

Efsti hluti öryggisbúrsins skal vera í samræmi við teikningar 253-12, 253-13 og 253-14.

Styrkingarnar mega fylgja þaklínunni.

Fyrir keppnir án aðstoðarökumanns þar sem farið er eftir teikningu 253-12 þarf aðeins eina stífu með fremri festingu ökumannsmegin.

Endar styrkinganna skulu vera innan við 100mm frá samtengingum veltiboga og þverstífa. Þetta á ekki við V-ið sem sýnt er á teikningum 253-13 og 253-14.

##### Samtenging á V

Nái stífurnar ekki saman má bilið milli þeirra ekki vera meira en 100mm.



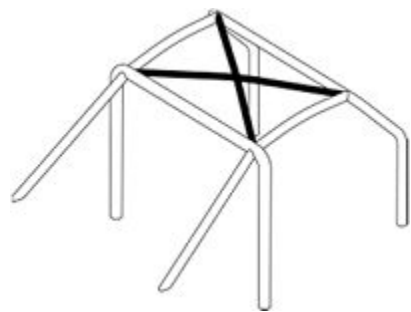

253-12

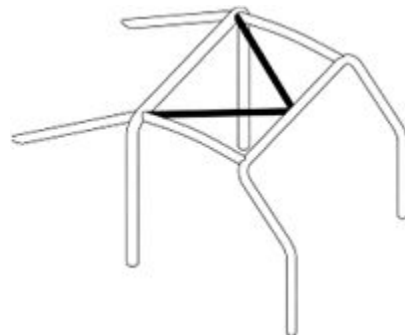

253-13

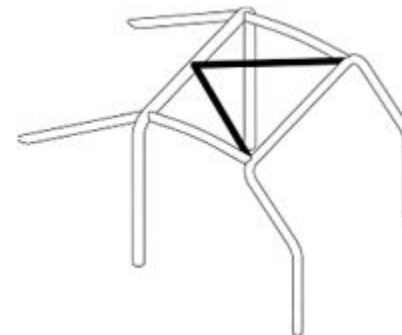

253-14

#### 8.3.2.1.4 Windscreen pillar reinforcement

It must be fitted on each side of the front rollbar if dimension "A" is greater than 200 mm (Drawing 253-15).

It may be bent on condition that it is straight in side view and that the angle of the bend does not exceed 20°.

Its upper end must be less than 100 mm from the junction between the front (lateral) rollbar and the longitudinal (transverse) member (see Drawing 253-52 for the measurement).

Its lower end must be less than 100 mm from the (front) mounting foot of front (lateral) rollbar.

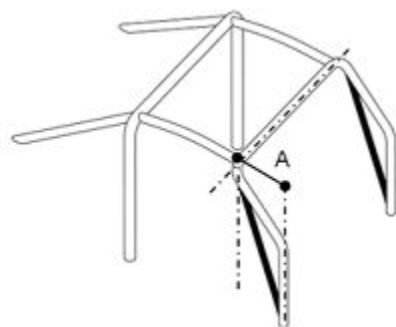

253-15

#### 8.3.2.1.5 Reinforcement of bends and junctions

The junctions between :

- The diagonal members of the main rollbar

#### 8.3.2.1.4 Gluggastífur

Þær skal setja á báðar hliðar fremri veltiboga ef "A" er lengra en 200mm (teikning 253-15).

Heimilt er að beygja hana, en hún skal vera bein þegar horft er á hlið og beygjuhornið sé ekki stærra en 20°.

Efri festipunkturinn skal vera innan við 100mm frá samskeytum veltiboga og þverstífu (sjá teikningu 253-52 fyrir málsetningu).

Neðri festipunkturinn skal vera innan við 100mm frá fótplötu fremri veltiboga.

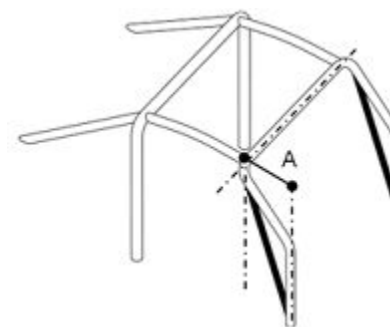

253-15

#### 8.3.2.1.5 Styrkingar á beygjum og samtengingum.

Samtengingar milli:

- Skástífa í aðalveltiboga.

<ul style="list-style-type: none"> <li>• The roof reinforcements (Drawing 253-12)</li> <li>• The doorbars (configuration of Drawing 253-9)</li> <li>• The doorbars and the windscreen pillar reinforcement (Drawing 253-15) must be reinforced by a minimum of 2 gussets complying with Article 253-8.2.14.</li> </ul> <p>If the doorbars and the windscreen pillar reinforcement are not situated in the same plane, the reinforcement may be made of fabricated sheet metal, provided it complies with dimensions in Article 253-8.2.14.</p>	<ul style="list-style-type: none"> <li>• Þakstyrkinga (teikning 253-12)</li> <li>• Hurðabita (teikning 253-9)</li> <li>• Hurðabita og gluggastífa (teikning 253-15)</li> </ul> <p>skulu vera styrktar með að minnsta kosti tveimur áfellum, samkvæmt grein 253-8.2.14. Þegar styrkingar hurðabita og gluggastífa liggja ekki í sama plani mega styrkingar vera gerðar úr stálplötu, að því gefnu að það uppfylli 253-8.2.14.</p>
<p><b>8.3.2.2 Optional members and reinforcements</b></p> <p>Except other indications given in Article 253-8.3.2.1, members and reinforcements shown in Drawings 253-12 to 253-21 and 253-23 to 253-33 are optional and may be installed as desired by the constructor.</p> <p>They must be either welded or installed by means of dismantlable joints.</p> <p>All members and reinforcements mentioned above may be used separately or combined with one another.</p>	<p><b>8.3.2.2 Aukastífur og styrkingar</b></p> <p>Nema annað sé tekið fram í grein 253-8.3.2.1, má setja stífur og styrkingar sem sýndar eru á teikningum 253-12 til 253-21 og 253-23 til 253-33 eftir því sem hönnuði smíðinnar þóknast.</p> <p>Þær þurfa annað hvort að vera soðnar eða settar sem laustengdar stífur.</p> <p>Nota má allar aukastífur og styrkingar sem nefndar eru hér að ofan einar og sér eða sameinað með öðrum.</p>
<p><b>8.3.2.2.3 Backstay diagonals (Drawing 253-21)</b></p> <p>The configuration of Drawing 253-21 may be replaced with that of Drawing 253-22 if a roof reinforcement complying with Drawing 253-14 is used.</p> <p><u>For cars homologated as from 01.01.2014 :</u></p> <p>The configuration of Drawing 253-22 is compulsory if a roof reinforcement complying with Drawing 253-14 is used.</p>	<p><b>8.3.2.2.3 Styrkingar í bakstífur (teikning 253-21)</b></p> <p>Í stað bakstífustyrkinga samkvæmt teikningu 253-21 má nota styrkingar eins og sýndar eru á teikningu 253-22, sé þakstyrking samkvæmt teikningu 253-14.</p> <p>Hönnun þakstyrkingar eins og sýnd er á teikningu 253-14 skyldar notkun bakstífustyrkinga samkvæmt teikningu 253-22.</p>
<p><b>8.3.2.2.4 Front suspension mounting points (Drawing 253-25)</b></p> <p>The extensions must be connected to the front suspension top mounting points.</p>	<p><b>8.3.2.2.4 Tengipunktur við fremri dempararnum (teikning 253-25)</b></p> <p>Frömlengingin skal vera tengd við efsta tengipunkt dempararnum.</p>
<p><b>8.3.2.2.5 Transverse members (Drawings 253-26 to 253-30)</b></p> <p>Transverse members fitted on the main rollbar or between the backstays may be used for the safety harness mountings in accordance with Article 253-6.2 (use of dismantlable joints is prohibited).</p> <p>For members shown on Drawings 253-26 and 253-27, the angle between the central leg and the vertical must be at least 30°.</p> <p>The transverse member fixed to the front rollbar must not encroach upon the space reserved for the occupants.</p> <p>It may be placed as high as possible but its lower edge must not be higher than the uppermost point of the dashboard.</p> <p>It must not be positioned below the steering column.</p>	<p><b>8.3.2.2.5 Þverstífur (teikningar 253-26 til 253-30)</b></p> <p>Þverstífur sem eru festar á aðal veltiboga eða milli bakstífa má nota sem festipunkta fyrir öryggisbelti í samræmi við grein 253-6.2 (ekki má nota laustengdar stífur).</p> <p>Fyrir stífur sýndar á teikningum 253-26 og 253-27 verður hornið milli miðstífunnar og lóðréttrar línu að vera að minnsta kosti 30°.</p> <p>Þverstífa sem fest er í fremri veltiboga má ekki þrengja að ökumansrými. Hún má vera eins hátt og mögulegt er, en lægri endinn má ekki vera hærri en hæsti punktur mælaborðs.</p> <p>Óheimilt er að stífan sé fyrir neðan stýristúbu.</p>
<p><b>8.3.2.2.6 Reinforcement of bends or junctions (Drawings 253-31 to 253-34)</b></p>	<p><b>8.3.2.2.6 Styrkingar á beygjum og samtengingum (teikningar 253-31 til 253-33)</b></p>

Reinforcements must be made of tubes or bent-sheet metal with U shape complying with Article 253-8.2.14.

The thickness of the components forming a reinforcement must not be less than 1.0 mm.

The ends of the tubular reinforcements must not be more than half way down or along the members to which they are attached, except for those of the junction of the front rollbar, which may join the junction of the door strut/front rollbar.

Styrkingar verða að vera úr rörum eða U-beygðum málmplötum í samræmi við grein 253-8.2.14.

Veggjaþykkt á styrkingum má ekki vera minni en 1,00mm.

Endar rörastyrkinga mega ekki ná lengra en hálfa leið eftir þeirri stífu sem þær tengjast, undantekning er þó styrking samkvæmt teikningu 253-33.

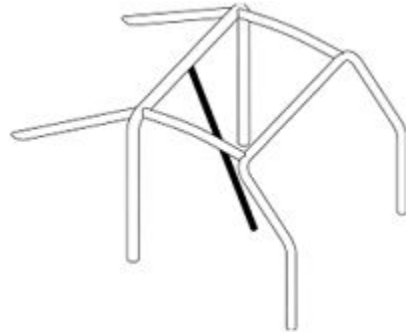

253-16

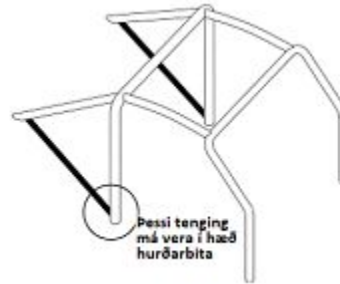

253-17

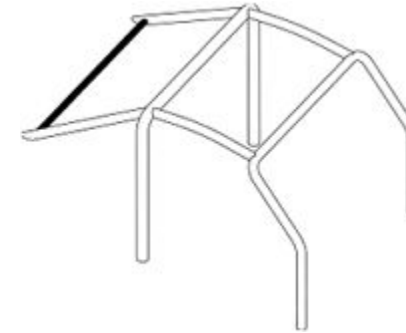

253-18

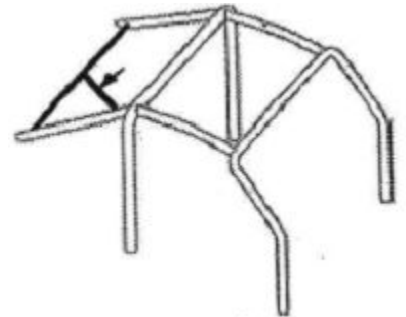

253-18B !! Provisional !!

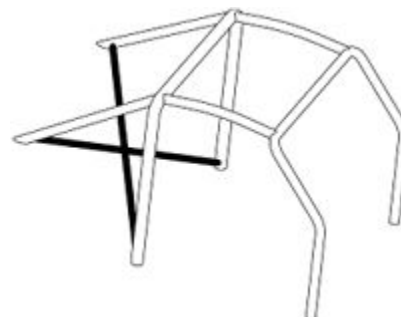

253-19

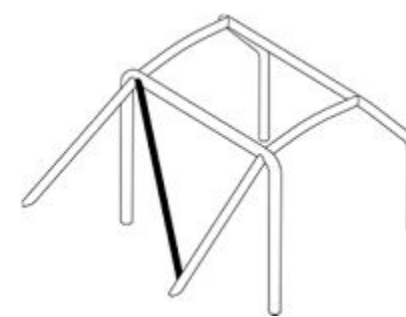

253-20

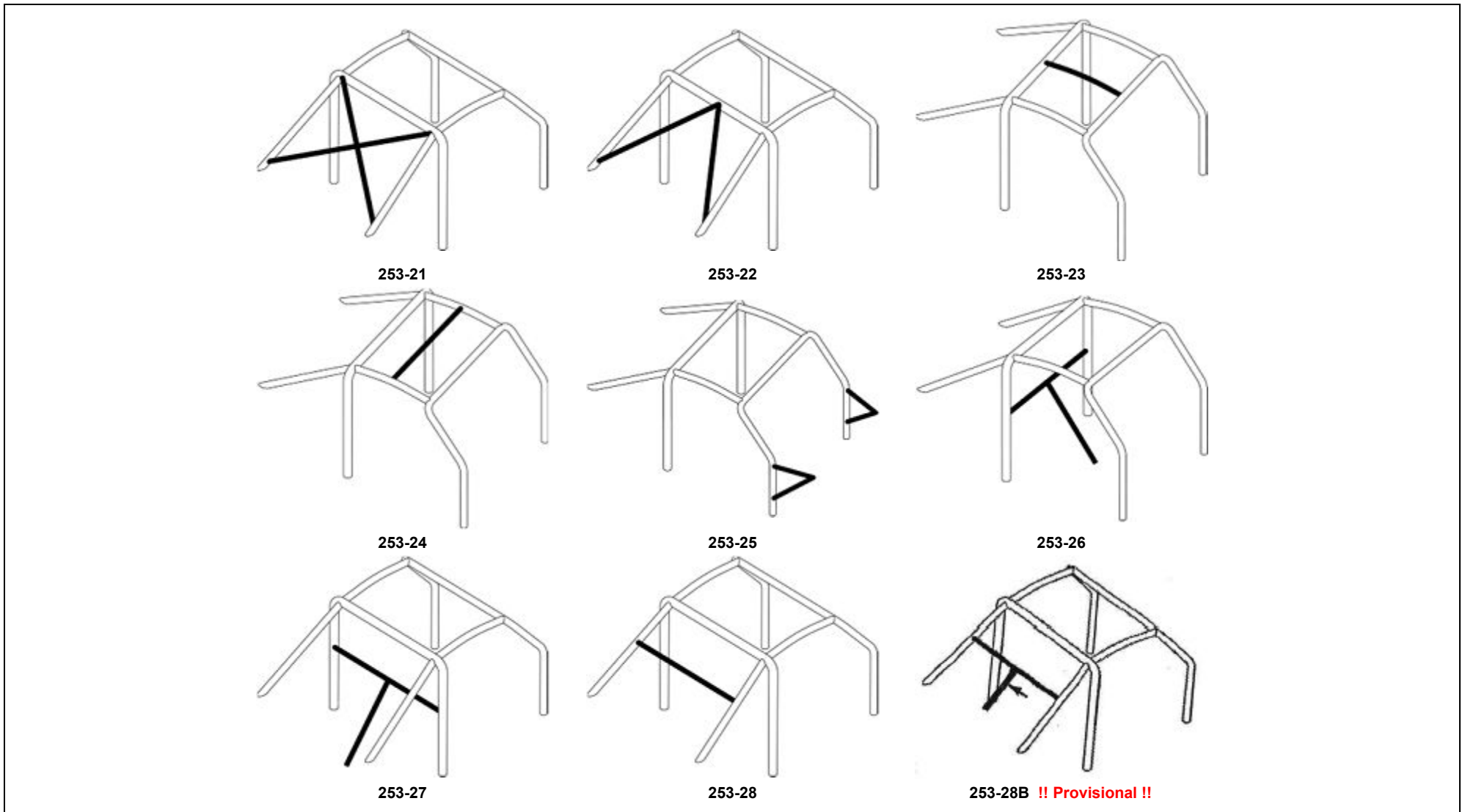

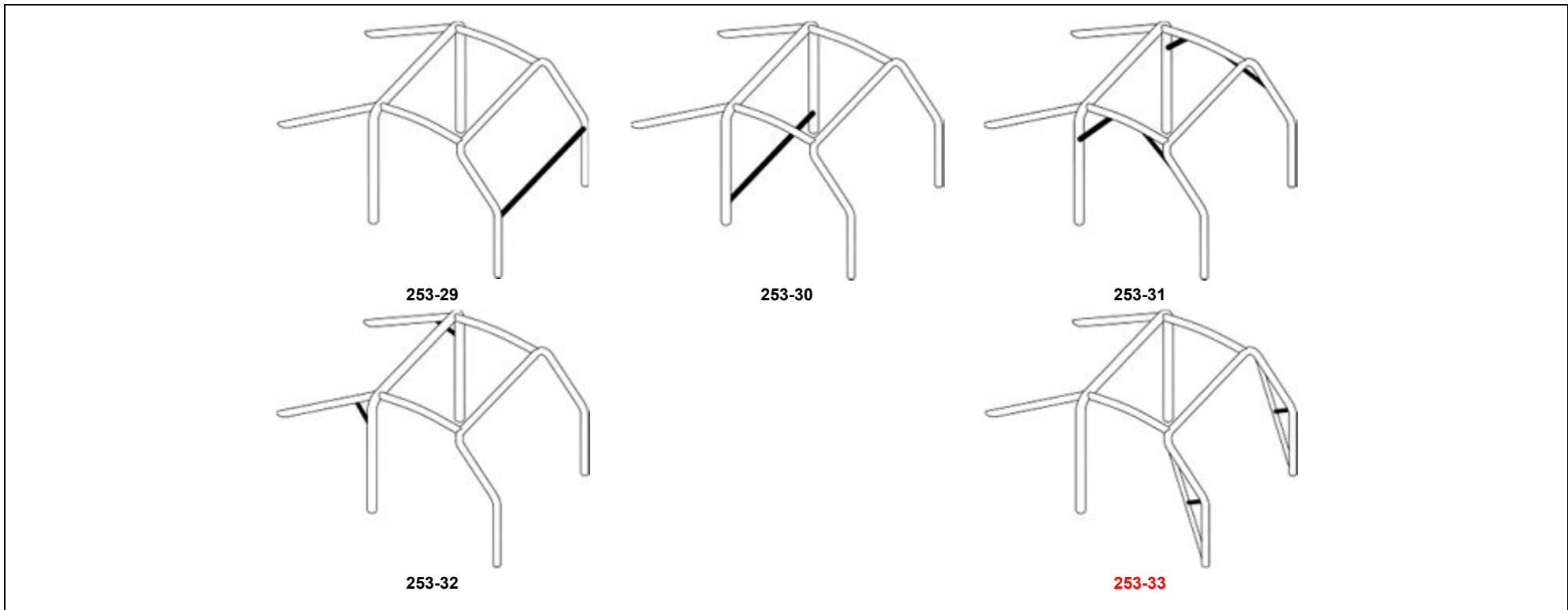

**8.3.2.3 Minimum configuration of the safety cage**

The minimum configuration of a safety cage is defined as follows :

Með aðstoðarökumanni  
Teikning 253-35C

Án aðstoðarökumanns  
Teikning 253-36C or symmetrical

Doorbars and roof reinforcement may vary according to Articles 253-8.3.2.1.2 and 253-8.3.2.1.3.

**8.3.2.3 Lágmarkskröfur um skipulag öryggisbúrsins**

Lágmarkskröfur um skipulag öryggisbúrsins eru skilgreindar svona:

Með aðstoðarökumanni  
Teikning 253-35C

Án aðstoðarökumanns  
Teikning 253-36C or symmetrical

Hurðabitar og þakstyrkingar mega vera breytilegar í samræmi við greinar 253-8.3.2.1.2 og 253-8.3.2.1.3.

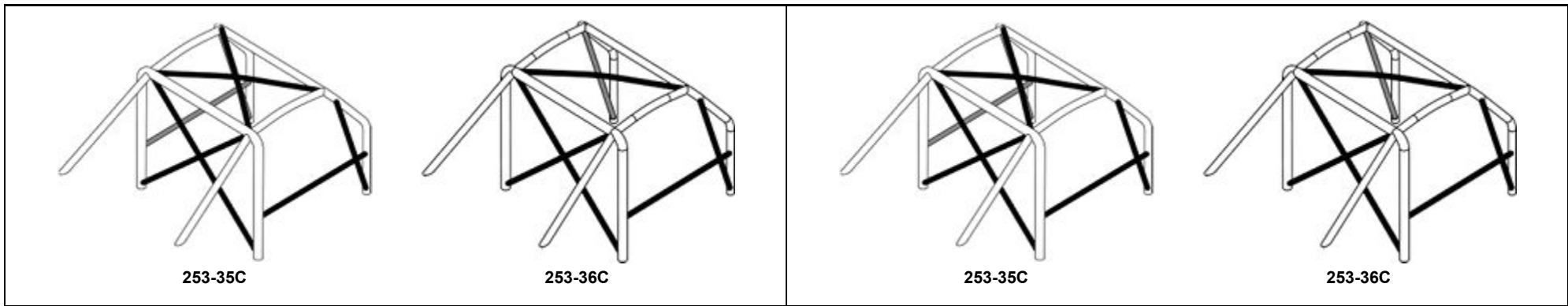

#### 8.3.2.4 Removable members

Should removable members be used in the construction of a safety cage, the dismantlable joints used must comply with a type approved by the FIA (Drawings 253-37 to 253-47).

They must not be welded once assembled.

The screws and bolts must have a minimum quality of 8.8 (ISO standard).

Dismountable joints complying with Drawings 253-37, 253-40, 253-43, 253-46 and 253-47 are solely for attaching optional members and reinforcements described by Article 253-8.3.2.2, and are forbidden for joining the upper parts of the main rollbar, of the front rollbar, of the lateral half-rollbars and of the lateral rollbars.

#### 8.3.2.4 Færanlegar stífur

Þegar laustengðar stífur eru notaðar í smíði öryggisbúrs þurfa samtengingarnar að vera til samræmis við teikningar 253-37 til 253-47.

Þær má ekki sjóða eftir samtengingu.

Rær og boltar þurfa að vera að lágmarki 8.8 að styrk (ISO staðall).

Samtengingar samkvæmt teikningum 253-37, 253-40, 253-43, 253-46 og 253-47 eru eingöngu ætlaðar fyrir aukastífur og styrkingar eins og lýst er í grein 253-8.3.2.2 og má ekki nota til að tengja efri hluta veltiboga, fremri veltiboga, langtenda hálf-veltibogans og langtengda veltibogans.

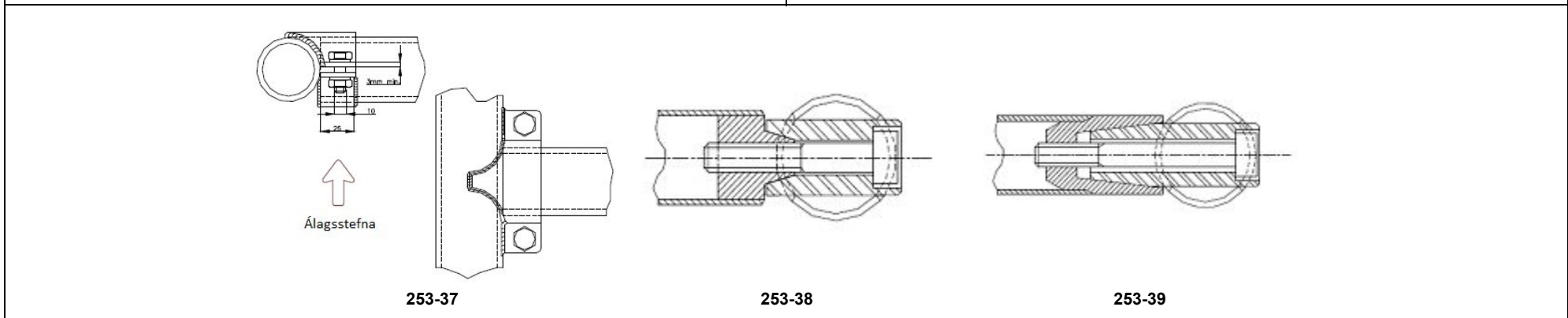

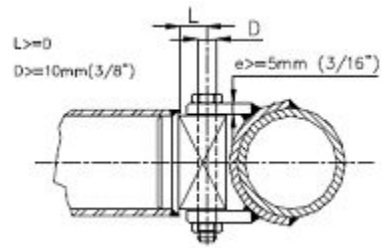

253-40

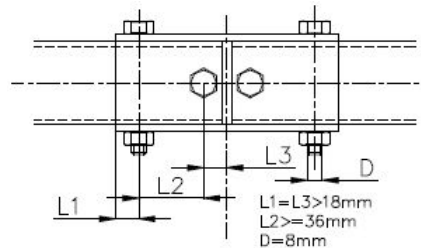

253-41

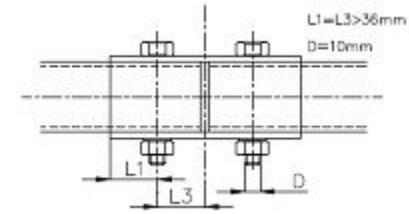

253-42

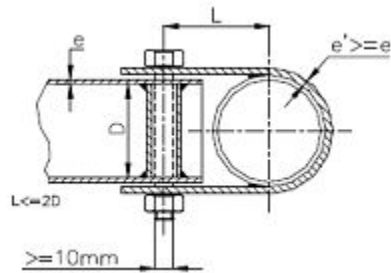

253-43

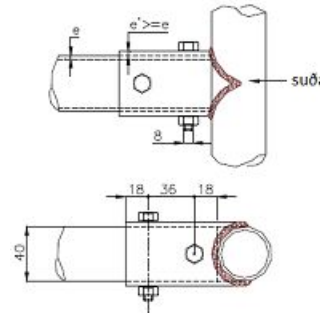

253-44

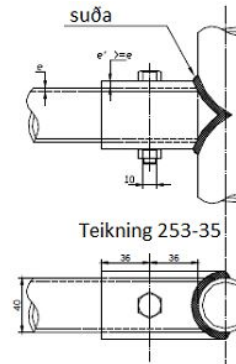

253-45

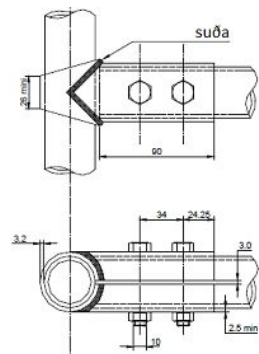

253-46

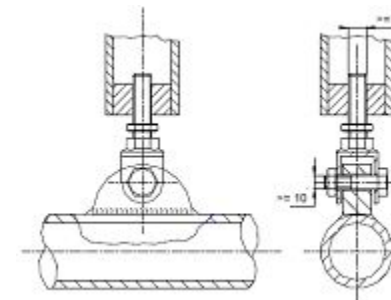

253-47

### 8.3.2.5 Additional constraints

Longitudinally, the safety cage must be entirely contained between the mounting points of the front and rear suspension elements carrying the vertical loads (springs and shock absorbers).

Supplementary reinforcements exceeding these limits are authorised between the

### 8.3.2.5 Aðrar takmarkanir

Öryggisbúrið skal vera á milli fremri og aftari festipunkta fjórðunarkerfis sem bera þyngd bílsins.

Aukastyrkingar sem ná aftur fyrir þessi mörk eru leyfðar milli öryggisbúrs og festipunkta jafnvægisstangar í grind eða yfirbyggingu bíls.

safety cage and the anchorage points of the rear antiroll bars on the bodyshell/chassis. Each of these anchorage points may be connected to the safety cage by a single tube with dimensions of 30 x 1.5mm.

In frontal projection, reinforcements of bends and junctions of the upper corners of the front roll-cage must be only visible through the area of the windscreen described by Drawing 253-48.

The presence of the cage reinforcements in the door aperture must comply with the following criteria (Drawing 253-49) :

- Dimension A must be a minimum of 300 mm
- Dimension B must be a maximum of 250 mm
- Dimension C must be a maximum of 300 mm
- Dimension E must not be more than half the height of the door aperture (H).

Hver festipunktur má tengjast við öryggisbúrið með einni stífu af sverleika 30 x 1,5mm. Þegar horft er á búrið að framan mega styrkingar á beygjum og samtengingum aðeins vera sýnilegar til samræmis við teikningu 253-48

Styrkingar í dyraopi verða að vera til samræmis við teikningu 253-49:

- Lengd A skal vera minnst 300mm
- Lengd B skal vera lengri en 250mm
- Lengd C skal vera lengri en 300mm
- Lengd E má ekki vera lengri en helmingur af hæð dyraops (H).

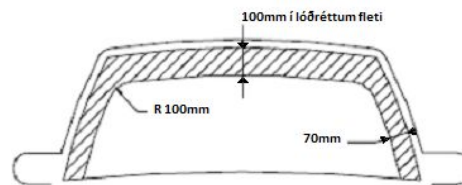

253-48

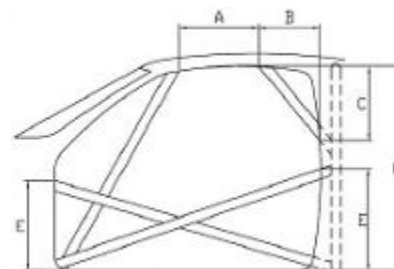

253-49

### 8.3.2.6 Mounting of safety cages to the bodyshell/chassis

Minimum mounting points are :

- 1 for each pillar of the front rollbar
- 1 for each pillar of the lateral rollbars or lateral half-rollbars
- 1 for each pillar of the main rollbar
- 1 for each backstay

To achieve an efficient mounting to the bodyshell, the original interior trim may be modified around the safety cages and their mountings by cutting it away or by distorting it.

However, this modification does not permit the removal of complete parts of upholstery or trim.

Where necessary, the fuse box may be moved to enable a safety cage to be fitted.

#### **Mounting points of the front, main, lateral rollbars or lateral halfrollbars:**

Each mounting point must include a reinforcement plate at least 3 mm thick.

### 8.3.2.6 Festingar öryggisbúrs við grind eða yfirbyggingu

Minnsti fjöldi festipunkta er:

- 1 fyrir hverja stoð fremri veltiboga
- 1 fyrir hverja stoð langtengds veltiboga eða langtengds hálf-veltiboga
- 1 fyrir hverja stoð aðalveltiboga
- 1 fyrir hverja bakstífu

Til að fá trausta festingu við yfirbyggingu má aðlaga innréttingu að öryggisbúrinu og festingum þess með því að skera burt eða aflaga að hluta.

Hins vegar leyfir þessi breyting ekki að fjarlægðir séu heilir hlutar innréttingarinnar. Þar sem nauðsyn krefur, má færa öryggjabox til að koma fyrir öryggisbúri.

#### **Fótplötur fyrir fremri, aðal, langtengds veltiboga eða langtengds hálf-veltiboga:**

Hver fótplata þarf að hafa styrktarplötu sem er minnst 3mm þykk.

Hver fótplata þarf að vera fest með að lágmarki 3 boltum á styrktarplötu sem er að minnsta kosti 3mm þykk og að minnsta kosti 120cm<sup>2</sup> yfirborð sem er soðið við



Each mounting foot must be attached by at least three bolts on a steel reinforcement plate at least 3 mm thick and of at least 120 cm<sup>2</sup> area which is welded to the bodyshell. For cars homologated as from 01.01.2007, the area of 120 cm<sup>2</sup> must be the contact surface between the reinforcement plate and the bodyshell.

Examples according to Drawings 253-50 to 253-56.

For Drawing 253-52, the reinforcement plate need not necessarily be welded to the bodyshell.

In the case of Drawing 253-54, the sides of the mounting point may be closed with a welded plate.

Fixing bolts must have a minimum diameter of M8 and a minimum quality of 8.8 (ISO standard).

Fasteners must be self-locking or fitted with lock washers.

The angle between 2 bolts (measured from the tube axis at the level of the mounting foot cf. Drawing 253-50) must not be less than 60 degrees.

#### **Mounting points of the backstays:**

Each backstay must be secured by a minimum of 2 M8 bolts with mounting feet of at least 60 cm<sup>2</sup> area (Drawing 253-57), or secured by a single bolt in double shear (Drawing 253-58), provided it is of adequate section and strength and provided that a bush is welded into the backstay.

#### **These are minimum requirements.**

In addition, more fasteners may be used, the support plates of the mounting feet may be welded to reinforcement plates, the safety cage (as defined by Article 253-8.3.1) may be welded to the bodyshell/chassis.

#### **Special case:**

For non-steel bodyshells/chassis, any weld between the cage and the bodyshell/chassis is prohibited, only the bonding of the reinforcement plate on the bodyshell/chassis is permitted.

yfirbyggingar.

Snertiflöturinn milli styrktarplötu og yfirbyggingar þarf að vera að lágmarki 120cm<sup>2</sup>. Dæmi eru teikningar 253-50 að 253-56.

Fyrir teikningu 253-52 þarf styrktarplatan ekki nauðsynlega að vera soðin við yfirbyggingu

Eigi teikning 253-54 við, mega hliðar fótplötunnar vera soðnar við yfirbygginguna. Boltar sem notaðir eru skulu vera að lágmarki M8 og styrkleiki að lágmarki 8.8 (ISO staðall)

Rær skulu vera sjálflæsandi eða notaðar spennskífum.

Hornið milli 2 bolta (mælt frá miðlínu stífunnar við fótplötuna í samræmi við teikningu 253-50 ) má ekki vera undir 60°.

#### **Fótplötur fyrir bakstífur:**

Hver bakstífa verður að vera fest með að minnsta kosti 2 M8 boltum á fótplötu sem er að minnsta kosti 60cm<sup>2</sup> (sjá teikningu 253-57) eða fest með einum bolta í vasa (sjá teikningu 253-58) svo fremi sem hann er af nægjanlegri þykkt og styrk og slíf sé soðin í bakstífuna fyrir festiboltann.

#### **Þetta eru lágmarkskröfur**

Að auki má nota fleiri festingar, stuðningsplötur undir fótplötur má sjóða fastar, öryggisbúrið (sem skilgreint er í grein 253-8.3.1) má sjóða við yfirbygginguna eða grindina.

#### **Sértilvik:**

Fyrir yfirbyggingu eð grind sem ekki er úr stáli, má engin suða vera milli öryggisbúrs og yfirbyggingar eða grindar, eingöngu má festa styrktarplötuna við yfirbyggingu eða grind.

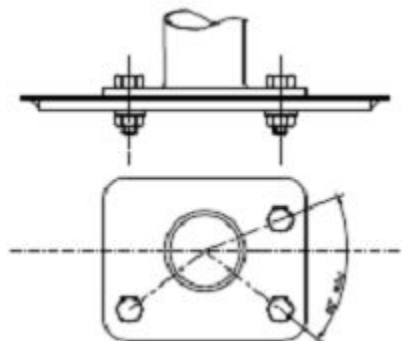

253-50

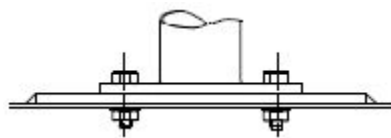

253-51

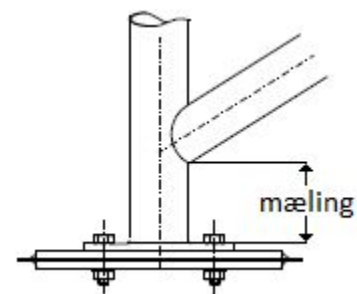

253-52

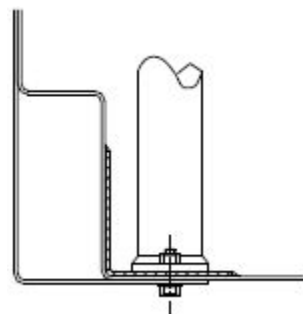

253-53

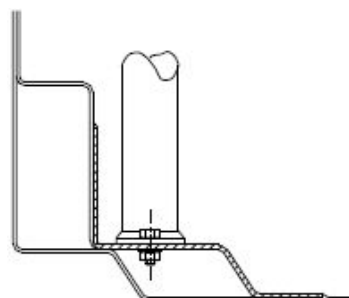

253-54

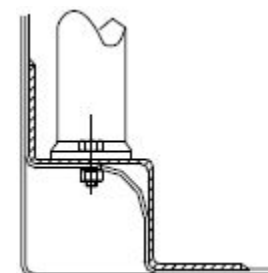

253-55

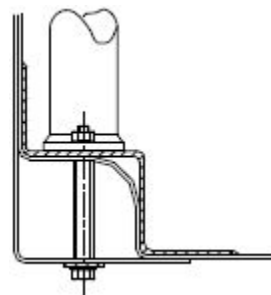

253-56

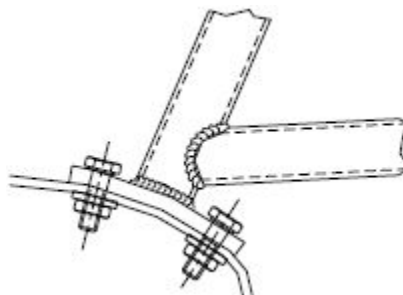

253-57

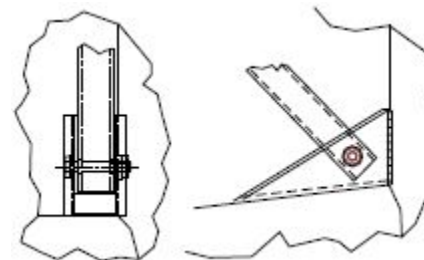

253-58

### 8.3.3 Tube specifications

Only tubes with a circular section are authorised.

#### Specifications of the tubes used :

### 8.3.3 Forskriftir röra

Eingöngu eru leyfð sem eru með hringlaga þversniði.

#### Forskriftir röra sem má nota:

Material	Minimum tensile strength	Minimum Dimensions (mm)	Use
Cold drawn seamless unalloyed carbon steel (see below) containing a maximum of 0.3 % of carbon	350N/mm2	45 x 2.5 (1.75"x0.095") or 50 x 2.0 (2.0"x0.083")	Main rollbar (Drawings 253-1 and 253-3) or Lateral rollbars and Rear transverse Member (Drawing 253-2)
		38 x 2.5 (1.5"x0.095") or 40 x 2.0 (1.6"x0.083")	Lateral halfrollbars and other parts of the safety cage (unless otherwise indicated in the articles above)

**NOTE:**  
For unalloyed steel, the maximum content of additives is 1.7 % for manganese and 0.6 % for other elements.  
In selecting the steel, attention must be paid to obtaining good elongation properties and adequate weldability.  
The tubing must be bent by a cold working process and the centreline bend radius must be at least 3 times the tube diameter.  
If the tubing is ovalised during bending, the ratio of minor to major diameter must be 0.9 or greater.  
The surface at the level of the bends must be smooth and even, without ripples or cracks.

Efni	Lágmarks togstyrkur	Lágmarksstærðir	Notkun
Kaldheildregið kolefnisstál (sjá að neðan) með að hámarki 0,3% kolefni	350N/mm2	45 x 2.5 eða 50 x 2.0	Aðalveltibogi (Teikningar 253-1 og 253-3) eða Langtengdir veltibogar og aftari þverstífur (Teikning 253-2)
		38 x 2.5 eða 40 x 2.0	Langtengdir hálf-veltibogar og aðrir hlutar af öryggisbúri (nema annað sé tilgreint hér að ofan)

**Athugasemdir:**  
Fyrir hreint kolefnisstál er hámarks magn snefilefna 1,7% magnesíum og 0,6% af öðrum efnum.  
Þegar valið er stál verður að velja stál sem hefur góða góðan teygjanleika og vera gott til suðu.  
Rör verða að vera beygð án hita og er miðlína beygju að minnsta kosti þrefalt þvermál rörsins.  
Aflagist rörið við beygingu, verður hlutfall milli minnsta og mesta þvermáls vera 0,9 eða meira.  
Yfirboð röra í beygjunni verður að vera slétt, ókrumpað og ósprungið.

<p><b>8.3.4 Guidance on welding</b> These must be carried out along the whole perimeter of the tube. All welds must be of the highest possible quality with full penetration and preferably using a gas-shielded arc. Although good external appearance of a weld does not necessarily guarantee its quality, poor looking welds are never a sign of good workmanship. When using heat-treated steel the special instructions of the manufacturers must be followed (special electrodes, gas protected welding).</p>	<p><b>8.3.4 Leiðbeiningar um suðu</b> Suður þurfa að ná allan hringinn utan um rörin. Allar suður verða að vera af hæsta mögulega gæðaflokki með fullri gegnumsuðu og helst skal nota gassuður. Þó suða líti vel út þýðir það ekki endilega að gæðin séu í lagi, hinsvegar eru illa útlítandi suður aldrei merki um gott handbragð. Þegar stál sem hefur verið hitað er notað, verður að fylgja sérstökum leiðbeiningum sem framleiðandi gefur út (sérstök rafskaut, gasvernduð suða).</p>
<p><b>8.3.5 Protective padding</b></p>	<p><b>8.3.5 Hlífðarklæðning</b></p>

Where the occupants' bodies could come into contact with the safety cage, flame retardant padding must be provided for protection.

All tubes of the cage identified on drawing 253-68 and all roof reinforcements must be fitted with paddings in compliance with FIA standard 8857-2001 type A (see technical list n°23).

Each padding must be fixed in such a way that it is not moveable from the tube.

**Application:**

For all categories.

For competitions without co-driver, paddings are compulsory on driver's side only.

Þar sem líkamshlutar áhafnar gætu komist í snertingu við öryggisbúrið skal nota eldtefjandi klæðningu til varnar.

Öll rör sem eru merkt á teikningu 253-68 og allar þakstyrkingar skulu hafa hlífðarklæðningu í samræmi við FIA staðal 8857-2001, tegund A (sjá tæknilista nr. 23). Klæðningin skal vera fest þannig að ekki sé hægt að losa hana frá rörunum.

**Þessu skal fylgt í öllum keppnisgreinum.**

Fyrir keppnir án aðstoðarökumanns, þarf eingöngu hlífðarklæðningu ökumannsmegin.

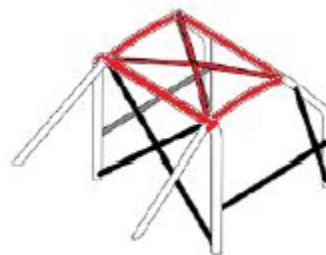

253-68